

Answer all questions. Answers must be written in the answer boxes provided.

- 1 (a) A small ball of mass  $m$  is moving in a horizontal circle on the inside surface of a frictionless conical bowl.

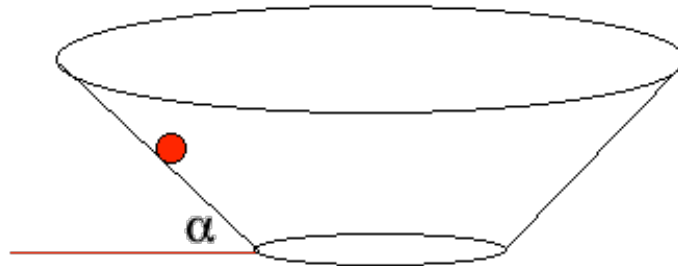

- (i) State the direction of the resultant force on the ball.

[1]

- (ii) On the diagram below, draw two arrows of the correct relative length to represent the normal force and weight of the ball.

[3]

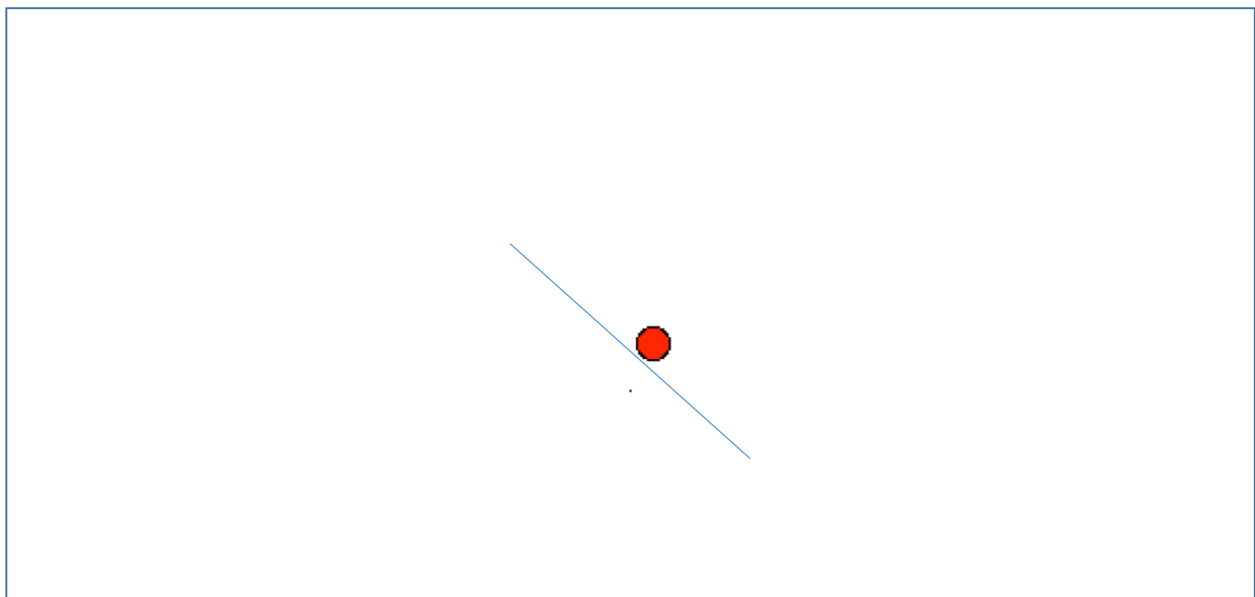

(iii) Show that the magnitude of the resultant force on the ball is given by:

[3]

$$F = \frac{mg}{\tan\alpha}$$

(iv) If  $\alpha = 45^\circ$  calculate the radius of the circle for a speed of  $1.2 \text{ ms}^{-1}$ .

[3]

(v) The ball is replaced by the bigger one shown below. Deduce whether or not this ball will follow the same path as the small one when travelling round the bowl at the same speed.

[2]



d) Two identical magnetic steel balls are placed in the bowl, one at the bottom and one at the top.

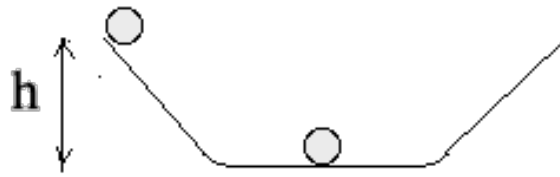

The upper ball is released and hits the lower ball. The two balls remain in contact. Show that the maximum height the balls could reach is  $h/4$ .

[3]

2. (a) A  $50 \text{ cm}^3$  syringe is filled with helium gas at room temperature (300 K) and atmospheric pressure (100 kPa). At this temperature and pressure helium behaves as an ideal gas.

(i) State what is meant by an ideal gas.

[1]

(ii) Calculate the number of moles of helium in the syringe.

[1]

(iii) Calculate the internal energy of the helium in joules.

[2]

(b) The end of the syringe is closed and the volume reduced to  $45 \text{ cm}^3$  at constant temperature.

(i) Calculate the new pressure in kPa.

[1]

(ii) Use the kinetic model to explain this change in pressure.

[2]

A large empty rectangular box with a thin blue border, intended for the student to write their explanation using the kinetic model.

3. (a) The diagram represents a slinky spring attached to a wall on the right and held in a hand on the left. The hand is moved left and right causing a longitudinal standing wave to be set up in the spring. The graph shows the displacement of the different coils of the spring at one moment in time.

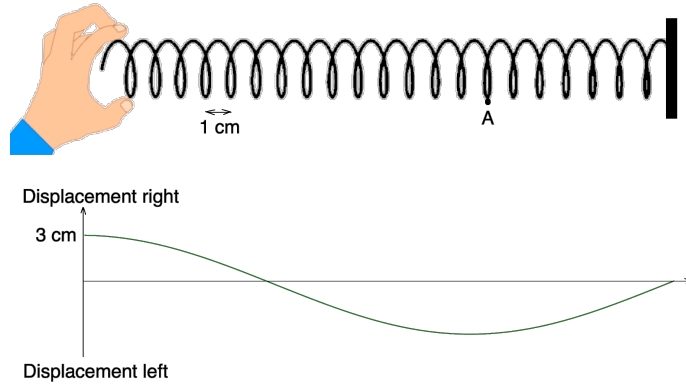

(i) Outline how the standing wave is formed.

[1]

Point A represents a point on the undisturbed spring.

(ii) Put a cross on the spring at the position of point A at the time of the graph.

[1]

(iii) Label two nodes on the spring with the letter N.

[1]

(iv) The frequency of the hand is 0.5 Hz. calculate the velocity of the wave.

[2]

(b) A sound wave from a distant source produces parallel wavefronts incident on the surface of a swimming pool at an angle just less than the critical angle.

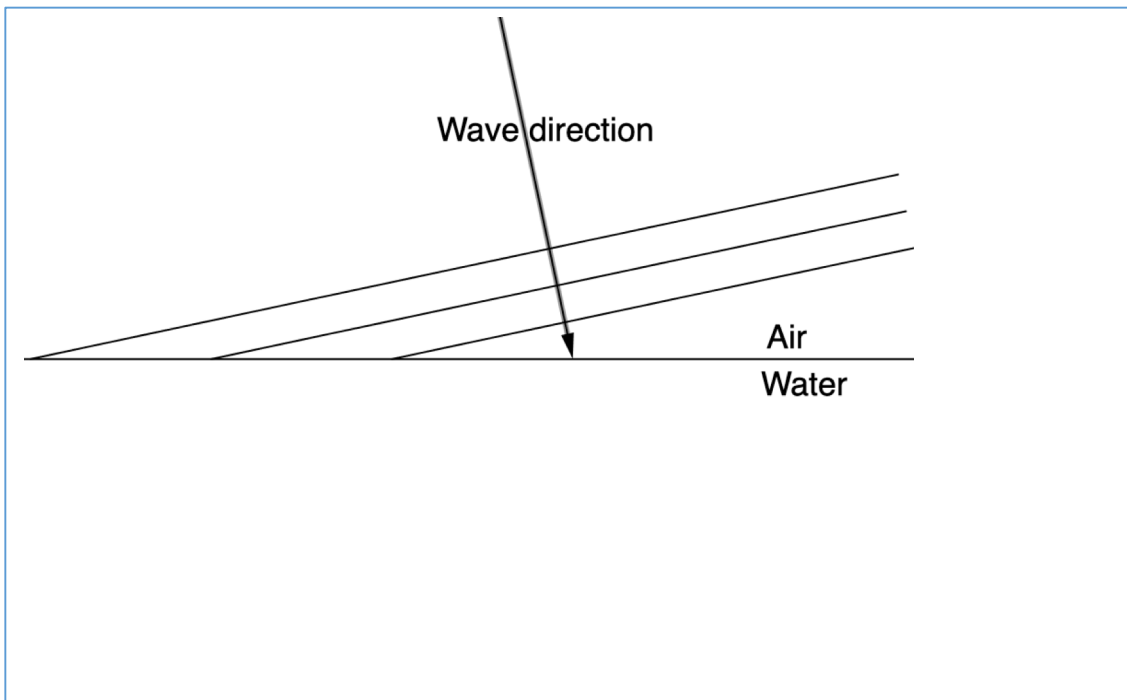

(i) State what is meant by the term critical angle.

[1]

(ii) Draw the 3 wavefronts after passing into the water.

[2]

(iii) The speed of sound in air is  $340 \text{ ms}^{-1}$  and in water  $1500 \text{ ms}^{-1}$ . Calculate the critical angle. Give your answer to the correct number of significant figures.

[2]

4. The circuit diagram represents a potential divider. The ammeter reads 0A

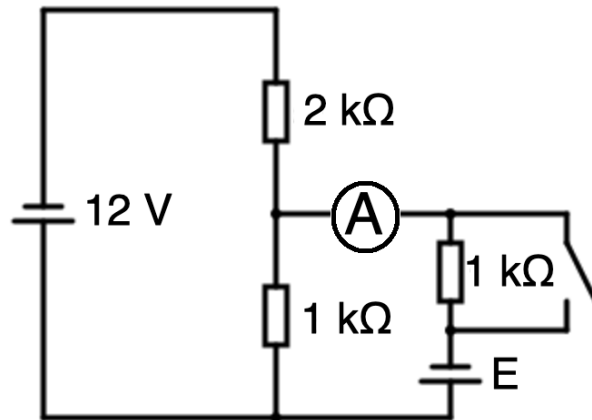

(a)

(i) E represents the emf of the cell, state what is meant by emf.

[2]

(ii) Determine E.

[2]

(iii) Deduce the effect, if any, that closing the switch would have on the ammeter reading.

[2]



5. During a storm a group of students investigate the feasibility of using rainwater collected on the roof of their physics lab to generate electrical energy. In 1 hour 16 mm of rain fell onto the  $100 \text{ m}^2$  roof of the building which is 5 m high. The density of water is  $1.00 \times 10^3 \text{ kgm}^{-3}$

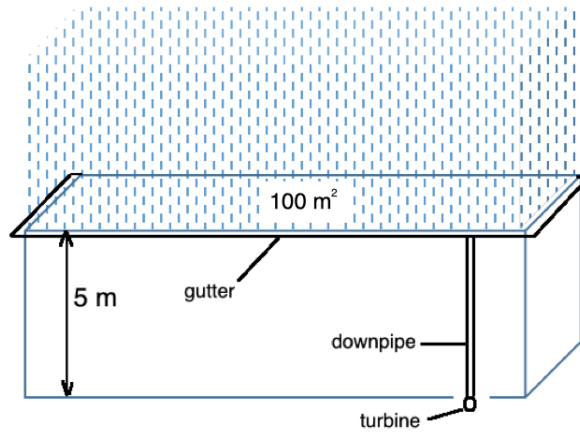

(a) Calculate the energy stored after 1 hour of rain.

[2]

(b) One plan was to pass the water through a turbine connected to the downpipe of the gutter system without collecting it in a tank. Assuming the turbine / generator is 100% efficient calculate the power output of the system.

[1]

(c) (i) An alternative plan was to collect the water in a tank then let it flow through the turbine. Calculate how the maximum time that a 100 W light bulb could be switched on for using this system.

[1]

(i) Explain why using a tank will result in the loss of energy.

[1]



6. (a) Describe the Rutherford model of the atom.

[2]

(b) Krypton - 90 ( ${}_{36}^{90}\text{Kr}$ ) is a possible result from the fission on a uranium nucleus.

(i) Explain why this nucleus decays by emitting a beta minus particle.

[2]

(ii) The binding energy per nucleon of Krypton - 90 is 8.59 MeV, this decays into rubidium – 90 which has a binding energy per nucleon of 8.63 MeV. Calculate the energy released in the decay.

[1]

(iii) Explain how the kinetic energy of the beta minus can be less than the energy released.

[2]